

SGP 2330 / 4330 Fully Automatic Strapping Machine



Standard Equipment

- Adjustable conveyor height
- Fold-out belt conveyor system
- Four swivel castors with brakes
- Closed strap arch system
- Heat seal
- Automatic strap feeder
- Automatic strap and ejection
- Strap loop ejection for cycles without product
- Cycle counter
- Electronic control system with microprocessor + Siemens S7-1200 PLC, free memory capacity for peripheral modules
- Machine-stop button
- Dispenser position: Side mounted
- Electrical power cable, 5m
- Basic photocell for detecting and positioning the package



Sigma Supply of North America, Inc.
824 Mid America Boulevard, Hot Springs, AR 71913

Phone: 501-760-1511
Fax: 501-760-1521
www.sigmasupply.com
equipment@sigmasupply.com

SGP 2330 / 4330

Technical Data / Layout

Technical Data

Heat weld sealing	
Preheating time	30 s
Electrical supply	Single phase AC 230 V / 50 Hz, 1PH and 115 V / 60 Hz, 1PH Tolerance -15%/+20% Main fuse 10 A

Performance at 225VAC	Mode Sleep	Mode Stand-by	Mode Oper.Max
Watt	50 W	70 W	607 W
Volt Amp	53 VA	78 VA	622 VA
Reactive Power	19 VAR	33 VAR	193 VAR
Power Factor	PF 0.61	PF 0.82	PF 0.98
COS Phi	0.94	0.91	0.99
Amp	0.28 A	0.38 A	3.0 A

Arch Dimension

Machines	Strap Width	Arch Dimension (WxH)	Strap Tension
SGP 2330 / 4330	5 mm (1/4")	650 x 500 mm (26 x 20")	300 N
	5 mm (1/4")	850 x 650 mm (33 x 26")	300 N
	9 / 12 mm (3/8" / 1/2")	650 x 500 mm (26 x 20")	450 N
	9 / 12 mm (3/8" / 1/2")	850 x 650 mm (33 x 26")	450 N
	9 / 12 mm (3/8" / 1/2")	850 x 850 mm (33 x 33")	450 N
	9 / 12 mm (3/8" / 1/2")	850 x 1250 mm (33 x 49")	450 N

Room temperature	10 - 40°C	(50 - 104°F)
Relative humidity	10 - 65%	
Cycles per minute up to* (without conveyor)	70/min.	
Conveyor	driven conveyor belt	
Conveyor speed, stepless	5 - 45 m/min (5.5 - 50 yd/min)	
Working heights	see layout	
Machine weight	300 kg	(660 lbs)
Color	Black RAL 9005, slate gray RAL 7015	
IP- Protection level	IP 56 / DIN 60529 + IPX9K / ISO 20653	

Packages

Width x height min.	100 x 50 mm	(4 x 2")
Width / height max.,	. / 50 mm	(. / 2")
Arch dimension		
Length min.	--	(8")
Weight max.	35 kg	(77 lbs)

Plastic Strap (PP)

Strap width	5 mm	(1/4")
	9 mm	(3/8")
	12 mm	(1/2")
Strap thickness	0.40 - 0.60 mm	(0.015 - 0.024")
Strap coil, Ø inside/outside	200 / 430 mm	(8" / 17")
Strap tension 5 mm (1/4")	300 N	
	9 - 12 mm (3/8 / 1/2")	450 N

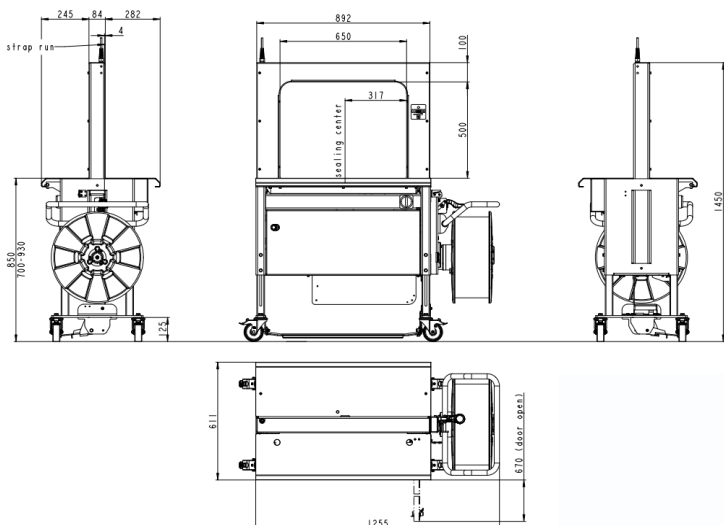

The polypropylene straps used for the respective applications must correspond with the strap specifications recommended by Signode!
*Performance: Depends on arch and package dimensions, conveyor speed, package distances and strap tension.